

BCF series Battery Chargers

Genset Controls - Timers/Monitors/Trips - **Battery Chargers** – Spares & Accessories - Custom Products

This range of 3, 6 and 10A CONSTANT POTENTIAL solid state battery chargers allow maintenance free charging of Lead-Acid batteries, over a wide ambient temperature range.

OPERATION : The electronic circuitry ensures that the battery is maintained at the correct 'Float Voltage' with negligible 'gassing'. As the battery is charged it's internal resistance rises, "tapering" the charge current accordingly, until the battery terminal voltage approaches the charger reference voltage, whereupon the battery is trickle charged to the "constant potential" float level.

Although the output current is not controlled electronically, it is limited by virtue of the transformer design. However, the output current can initially rise up to twice the rated current, for a short duration.

An auto-resetting 'Thermal-Trip' is positioned to monitor the temperature of the secondary winding & transformer laminations and is used to disconnect the primary winding.

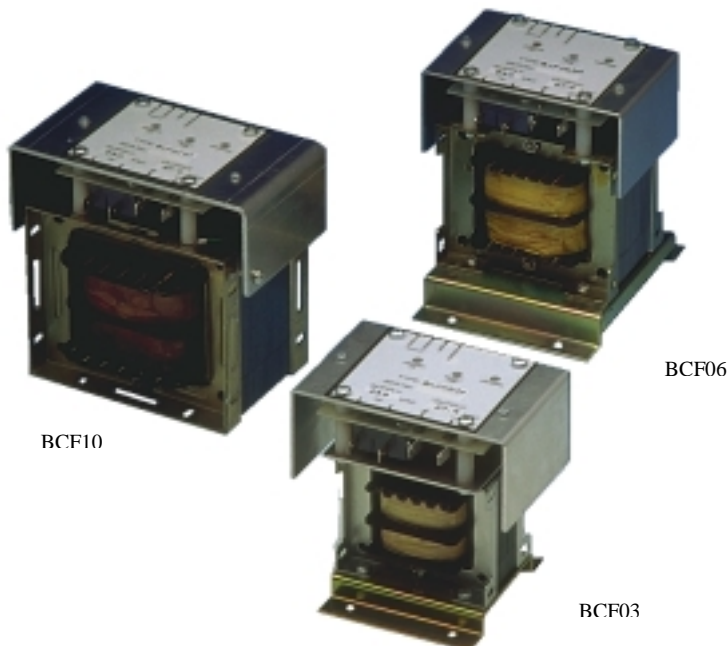

Note: Base Plates not fitted to BCF06 & BCF10 as standard

VOLTAGE THRESHOLD : Unless specified otherwise, all units are pre-set at : 2.3V/Cell 'Float' level. The potentiometer is factory calibrated (at centre scale) and should not normally require adjustment.

OVERRIDE (O/RIDE) TERMINALS : Linking these terminals - defeats the 'charge inhibit' protection (see above), enabling the charger to operate, even into a 'short-circuit' ! If these terminals are to be permanently linked it is recommended that this is done AFTER commissioning and an Output fuse is added.

CHARGER ON (LAMP) TERMINAL : A +Ve output to a Charge Failure Monitor (CFM400) & / or an external 'Charger On' lamp (100mA max. load).

CHARGING TERMINAL : A +Ve output for an external (incandescent) 'Charging' lamp (100mA max. load), to indicate when current is flowing into the battery. This is not suitable to drive a relay.

LEAKAGE CURRENT : Approx. 2mA

CONSTRUCTION : Mild steel (1mm) zinc plated and gold passivated base plate, frame transformer, aluminium heatsink, and printed circuit board assembly. The charger should be mounted so that the natural airflow passes through the heat sink.

LED INDICATORS : 'Charger-On' (Amber), 'Normal' (Green) & 'Fault' (Red)

SUPPLY VOLTAGE : 115 +/- 20% 50/60HZ or 230 +/- 20% 50/60HZ --- Specify on order

TEMPERATURE RANGE : -10 deg C to +55 deg C (operating) and -20 deg C to +70 deg C (storage)

TYPICAL APPLICATION

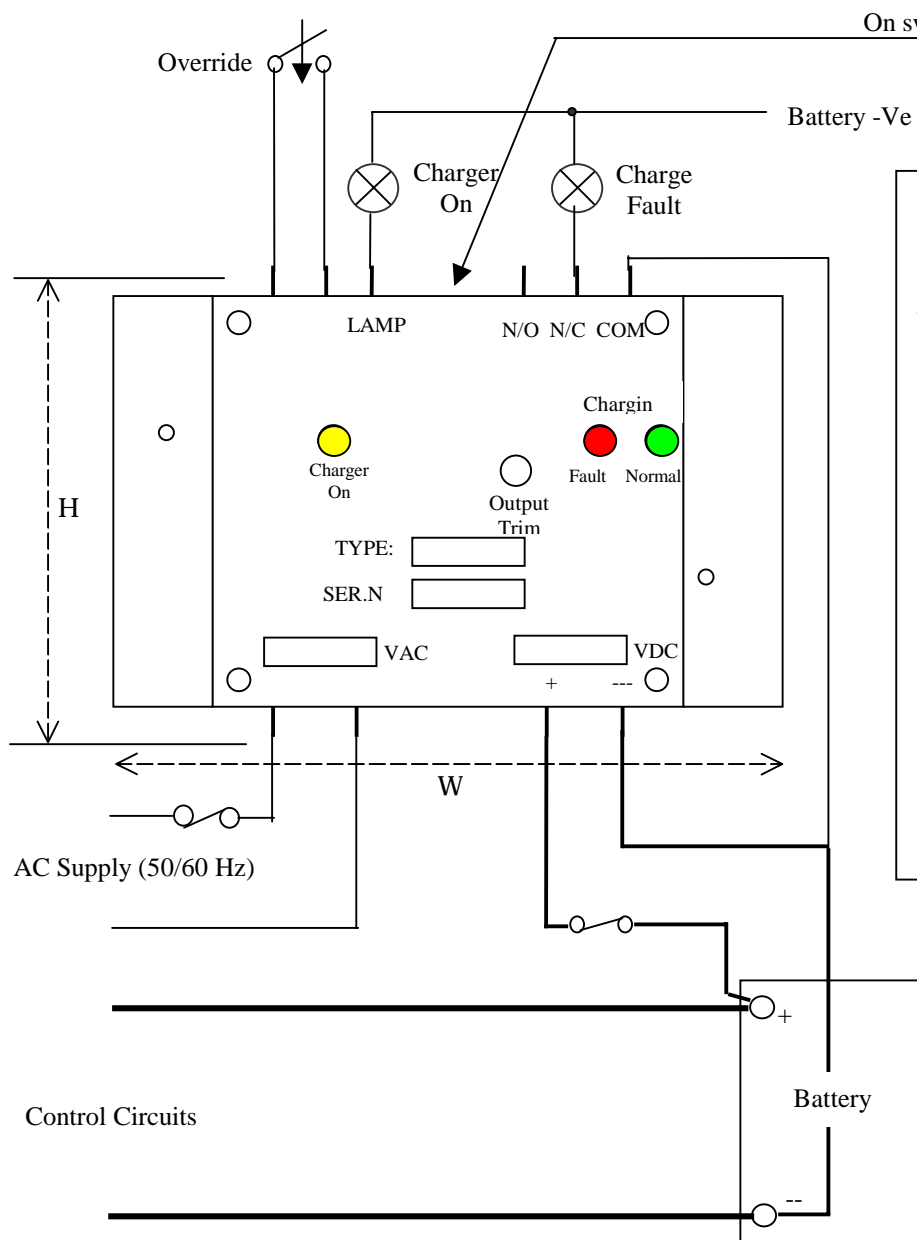

BCF06/24/230
SUPPLY CURRENT : 0.65A at 230V (150VA)
SUPPLY CABLES : Rate for 4.5A Inrush
EXTERNAL SUPPLY FUSE : 3A Anti-Surge (F1)

BCF06/24/115
SUPPLY CURRENT : 1.3A at 115V (150VA)
SUPPLY CABLES : Rate for 9A Inrush
EXTERNAL SUPPLY FUSE : 5A Anti-Surge (F1)

BCF06/24/---
OUTPUT CURRENT : 6A DC Average (> 12Amax.)
OUTPUT CABLES : Rate for 15A
OUTPUT FUSE : 15A Anti-surge (F2)

Sizes: L x H x D

BCF03: 92 x 115 x 122
 Fixing = 54 x 72 x M4
 BCF06/12: 115 x 92 x 115
 Fixing = 44 x 57 x M4
 BCF06/24: 115 x 92 x 125
 Fixing = 60 x 63 x M4
 BCF10/12: 95 x 140 x 120
 Fixing = 60 x 79 x M5
 BCF10/24: 105 x 140 x 135
 Fixing = 60 x 63 x M5

BCF03 includes Base Plate

Notes:

1. Fit 'Override' link after commissioning or to charge batteries < 1/2 Float Level.
2. 'Charge Fault circuit' fitted on standard charger.
3. Move slide switch to 'On' for Fault circuitry powered from Battery if 'loss of AC supply' is not a fault condition.
4. Relay de-energised in the Fault condition.
5. Fault Condition = Mains Failure (slide switch to 'Off') or Thermal Overload

CAPRICORN CONTROLS

Electronic Engineers - - Specialists in GenSet Controls

Unit 16, Thorpe Way, Banbury, Oxon. OX16 8SP England

Tel : + 44 (0)1295 272360 Fax : + 44 (0)1295 264766

E-mail: sales@capricorn-controls.com

Web: www.capricorn-controls.com