



KSM72 Key Start Module

Genset Controls - Timers - Monitors - Trips - Battery Charging - Spares & Accessories - Custom Products

Combining the convenience of manual operation with engine protection for Low Oil Pressure, Coolant Fault and (optionally) Overspeed, these 'short' Keystart Modules can be easily mounted into almost any control panel or switchbox. Set in a compact 72mmsq DIN sized module they can be used with a wide range of engine driven equipment.

The front panel has up to five 'High Intensity' LED's indicating system status. The key switch provides...



KSM72CH

PREHEAT

(KSM72_J option Only)

Select Pre-Heat if required, just prior to starting the engine. Use it for the shortest possible time to preserve charge in the battery (typically 10sec – but dependant on the ambient temperature).

Do not leave the switch in this position

See page-3 for 'Timed Pre-Heat' options.

OFF / RESET

Use to stop the engine and resets all Shutdowns. Always ensure that the engine is stationary before restarting.

RUN

Powers the unit, energises the fuel solenoid and starts the Hold-Off timer (T0). If the key remains in this position for 25sec's or more, the Hold-Off timer will elapse and the module will latch out on 'Low Oil Pressure'. To start the engine from an alarm condition, the key must first be turned to the 'OFF' position for at least 1 second (see above).

START

Hold in this position to crank the engine, releasing it to the 'Run' position as soon as the engine 'fires'. If the engine fails to start after approx. 10 sec's return the key to the 'OFF' position, wait approx. 10 sec's and try again. If the engine fails to start after three attempts, turn the key to the 'Off' position and consult the engine manufactures Handbook.

Assuming that the engine 'fires' the Keyswitch is returned to the RUN position, disengaging the Starter, the engine runs up to normal speed and the Hold-Off timer (T0) is running. The tachometer circuitry (KSM72B & D) continually monitors for Overspeed. When the hold-off timer has elapsed, the Low Oil Pressure and Cooling fault circuits are enabled. In the event of a shutdown, the appropriate fault Led is lit, the Alarm output (if applicable) is activated, the Fuel relay is locked out and the LOP & HET channels disabled (first-up interlock).

Ordering Information

Model No.	Overspeed	Channel 5 = Charge Failure	Channel 5 = 'Lamp Only'
KSM72A	No	No	see note 4
KSM72B	Yes	No	see note 4
KSM72C	No	Yes	No
KSM72D	Yes	Yes	No
Options	Features		Term.
* KSM72 - A (note 3)	Alarm Output +Ve from the N/C contact on the internal Fuel Control Relay		7
KSM72 - - H	Integral (LCD) 'Hours Counter'		
* KSM72 - - - - J	Switched 'Pre-Heat' +Ve output		7
**KSM72 - - - - Y	Pulsed output for Fuel pull-in coil + Timed Pre-Heat. i.e YANMAR engines.		9 & 10
* KSM72 - - - -Z	Timed 'Pre-Heat' +Ve output		7
Input Phasing			
KSM72 - - -	Het (Cooling Fault) & Lop (Low Oil Pressure) are both 'closed to ground' (Batt -Ve) on fault		
KSM72 - - - / HR	'Het Reversed' - open from ground (Batt -Ve) on fault		
KSM72 - - - / LR	'Lop Reversed' - open from ground (Batt -Ve) on fault		
KSM72 - - - / HLR	'Het & Lop Reversed' - {both of the above} - open from ground (Batt -Ve) on fault		

- NOTE: 1/ * These Models & Options are 'Mutually Exclusive' as they all use terminal 7, but for different functions!
- 2/ ** Builds with this option (KSM72A & C only) utilise term.9 & 10 for DC outputs and is therefore NOT compatible with KSM72B & D builds which use these terminals for 115 / 230Vac inputs.
- 3/ Unless requested otherwise, KSM72AA, BA, CA or DA are now supplied as standard.
- 4/ Connect term.7 to Batt -Ve to light LED 5. Various 'Over-Stick' labels can be supplied from stock.

SPECIAL BUILDS

KSM72 - - - / - - / X0? These 'X' numbers, indicate non-standard product, which have been manufactured to suit specific customer's requirements. They do not appear in any catalogues and may only be available to the original customer. When re-ordering, please quote the full part number together with the 'Serial Number' of the original unit(s).

CUSTOMISED PRODUCTS

If you have a specific requirement that is not listed above; please contact our Sales Desk for a quotation. We can normally customise a standard product within a matter of days in order to provide a prototype (if not, production) unit.

Note: - For a spare or replacement part, please quote the Serial Number of the original unit if possible.

Connections

Always ensure that the correct wire sizes are used and that all terminals are correctly tightened.

Terminal	Description	Type	Connect To -----
1 LOP	Low Oil Pressure	-Ve Input	Low Oil Pressure switch
2 HET	High Engine Temp.	-Ve Input	High Engine Temp. Switch
3 Starter	Max. Load 16 Amps (resistive) ♦	+Ve Output	Solenoid or Solenoid Relay
4 Batt+	Supply +Ve		Battery positive
5 Fuel	Max. Load 16 Amps (resistive) ♦	+Ve Output	Solenoid or Solenoid Relay
6 Batt -	Common DC -Ve supply		Battery negative
7 Exc+	(see below)		
8 C.F.	Charge Failure		Charging Alternator (WL)
9 AC	Frequency (Speed) sensing		115/230VAC (Main Alternator)
10 AC	Frequency (Speed) sensing		115/230VAC (Main Alternator)

NOTE : ♦ 'Max. Load 16 Amps (resistive)' de-rate to 14% for Inductive Loads (2.2A continuous)

BUILD OPTIONS

KSM72_A	<u>Unless requested otherwise, this option is now fitted on all standard builds.</u> Previously, special option " X069 " it provides a +Ve Alarm output (from the N/C contact on the internal Fuel Control relay). Whenever the engine is shutdown on a fault condition the Fuel Control relay de-energises, stopping the engine and providing a +Ve ALARM output rated at 16A (resistive) to directly drive a small sounder or power relay. An external 'flywheel' diode will be required with inductive loads. Please note:- At switch-on, the Alarm Output 'pulses' for approx. 20mSec.
KSM72_/X06	This special option provides a +Ve Alarm output whenever the engine is shutdown on a fault condition. Derived from the internal logic, it does not 'pulse' at switch on. The output has an integral 'flywheel' diode as it is designed to drive an external relay. <u>Continuous output current must not exceed 150mA.</u>
KSM72_H	An 'LCD' Hours Counter is fitted behind a windowed front label. It is powered in the 'Run' (or start) mode. An 'hour glass' indicator flashes every 6 th second to indicate that counting is in progress (only while the fuel solenoid is energised). Data retention is in excess of 20 years.
KSM72__J	The standard 'J' option provides a manual Pre-Heat position on the Keyswitch, anti-clockwise from 'OFF'. This +Ve Output is rated at 15Amps (resistive) and an external 'flywheel' diode is required if switching a solenoid, relay or other inductive load..
KSM72__Z	(KSM72A & KSM72C only) The standard 'Z' option provides a Timed Pre-Heat function (typically set to 12secs). An integral 'flywheel' diode is employed as it is designed to drive an inductive load, such as a relay. <u>Continuous output current must not exceed 150mA.</u> Please note: 'A', X06, 'J' & 'Z' Options are <u>Mutually Exclusive</u> as they all use term.7, but for different purposes.
KSM72___Y	(KSM72A & KSM72C only) this special option is for use with engines (i.e. Yanmar) with two-stage fuel solenoids (separate pull-in and hold coils). Terminals 9 & 10 provide drivers for external relays to operate the 1 sec 'fuel pulse' and 'Glowplugs'. <u>Continuous output current must not exceed 150mA.</u> This option does not include the standard 'A' Option as Exc+ is required.

WARNING: Builds with this option are incompatible with our standard range above as term.9 & 10 are normally reserved for 115/230V Frequency (Speed) sensing of the main alternator.

Application Notes

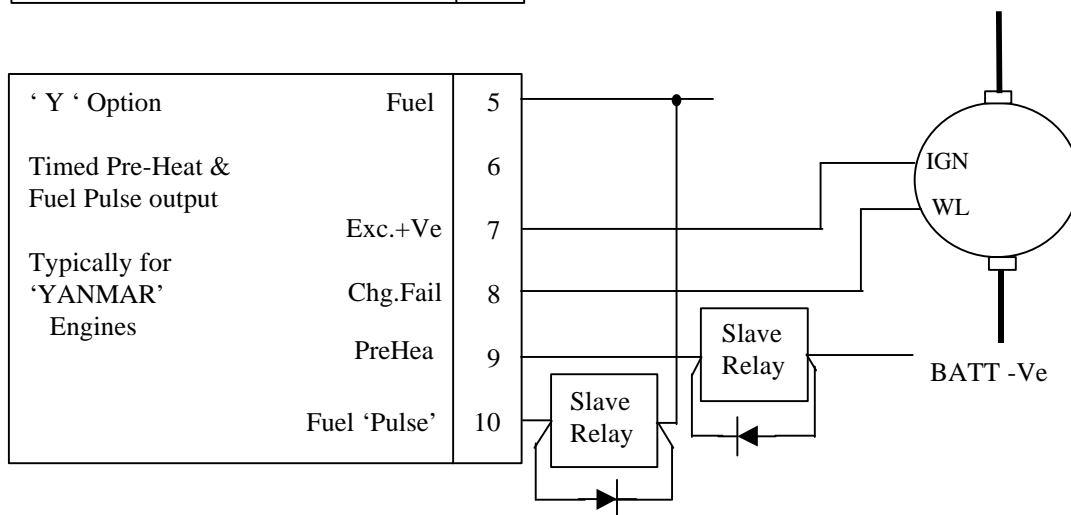
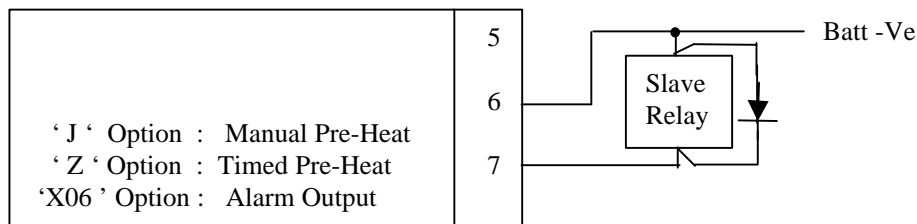
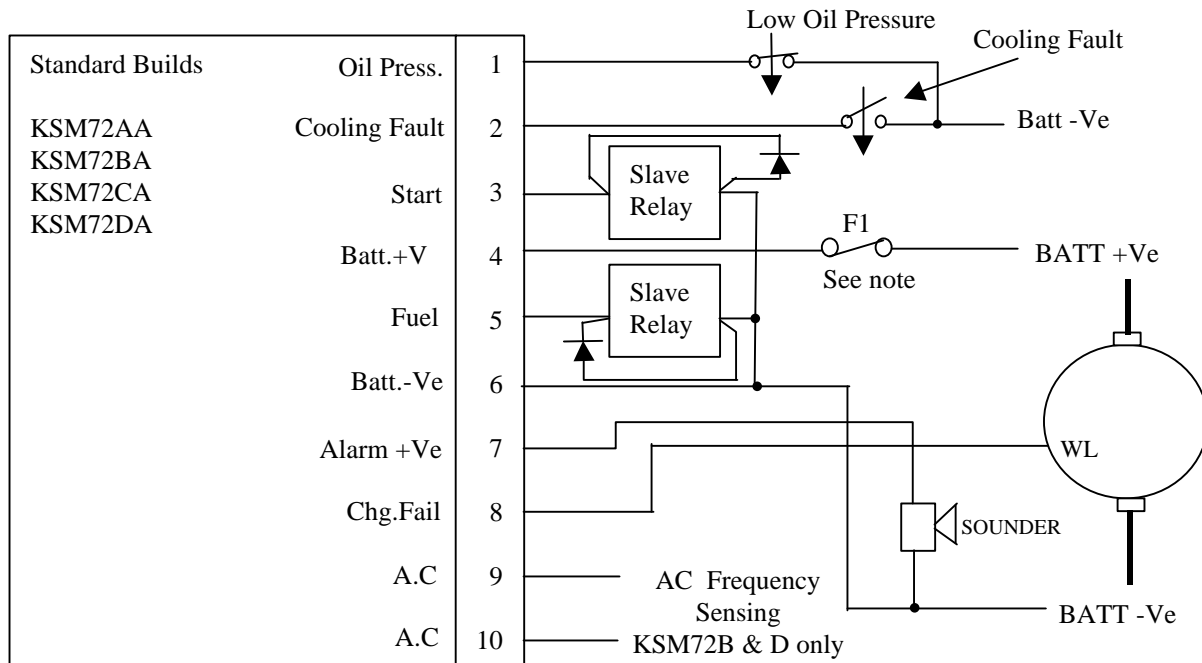

Notes

1. Oil Press. & Cooling Fault inputs are shown as 'close to ground' on fault.
2. Coolant Fault can be used to indicate 'High Engine Temperature' & / or 'Low Coolant Level'
3. Fuse F1 = 5A Anti-surge if Slave Relay on Fuel Solenoid, else 10A Anti-surge.
4. FUEL output = 16A resistive. (De-rate to 14% (2.2A continuous) to allow for 7x inrush into an inductive load)
5. START output = 16A resistive (direct from Keyswitch contacts).
6. For Slave Relays see 'Spares & Accessories' section of our latest 'Price List'.
7. All Slave Relays should have 'flywheel' suppression diodes fitted, to comply with EMC regulations ()

FAULT FINDING ----- KSM72 BASED SYSTEMS

Always check the 'obvious' first i.e. :

- ◆ System correctly wired
- ◆ Correct KSM72 type fitted for the specific application
- ◆ KSM72 suitably calibrated
- ◆ All connections use suitably rated cables to comply with all appropriate regulations.
- ◆ All terminal screw connections tight.
- ◆ Battery(s) charged, in good condition, clean & tight connections and of the correct voltage
- ◆ The Module **MUST** be fitted in a control panel with adequate protection from adverse Temperature, Moisture & Vibration

WARNING - Incorrect wiring might permanently damage the module i.e. -

- 1/ Loss of battery negative (term.6).
- 2/ Connecting any 'Active low' outputs directly to a positive supply.
- 3/ Connecting any positive DC outputs (i.e. Starter, Fuel, Exc.+, etc.) directly to a negative supply.
- 4/ Connecting any DC terminals to an AC supply.

- **Unit Dead - set will not start**

Check for battery supply on term.4(B+) and term.6(B-) of the KSM72 using a DC voltmeter

- **False tripping of Overspeed shutdown**

- (a) *Module requires calibration*
- (c) *Engine speed 'overshoots' on run-up.*
- (d) *External relays &/or Contactor coils may require noise suppression components.*

- **Low oil pressure shutdown**

- (b) *Faulty oil pressure switch, incorrect type or trip setting*
- (c) *Incorrect KSM72 type for use with oil pressure switch fitted*

- **Cooling Fault (High engine temp.) shutdown**

- (b) *Faulty temperature switch, incorrect type or trip setting*
- (c) *Incorrect KSM72 type for use with temperature switch fitted*

- **Charging Alternator fails to excite because**

- (a) *incorrect type of KSM72 fitted*
- (b) *rear mounted 82r resistor damaged, missing or too high a value (may require 47R on certain 12VDC Alternators).*

WARNING : Voltages dangerous to human life

Voltages **dangerous to human life** may be present at some of the terminal connections of this unit. Ensure all supplies are de-energised before attempting any connection / disconnection.

MOUNTING

The module must be fitted into a suitable control panel that provides adequate protection from the extremes of : Temperature, Humidity & Vibration. If this control panel is set-mounted then suitable 'Anti-Vibration' mounts **MUST** be used

SPECIFICATION

Supply 12/24V Single range supply, operating from 6V to 30VDC
 Drop out : < 4 VDC Absolute maximum input : 40VDC
 Burden : 70mA at 12VDC

Speed Sensing (KSM72B & D versions only)
 Main Alternator, sensing 50 Hz to 70 Hz at rated speed. 40V to 280Vac absolute maximum.

Functions Overspeed Trip Level factory pre-set to 57Hz or 68Hz (unless specified otherwise)
 Hold-Off Timer 25 sec fixed

Fault Inputs
 Low Oil Pressure Normally Open, close to Batt.-Ve on fault (unless otherwise stated)
 Cooling Fault Normally Open, close to Batt.-Ve on fault (unless otherwise stated)

Outputs FUEL output 16A resistive. De-rate to 14% (2.2A) to allow for 7x inrush
 START output 16A resistive. De-rate to 14% (2.2A) to allow for 7x inrush
 Exc.+Ve output < 1A maximum
 ALARM output 16A resistive. De-rate to 14% (2.2A) to allow for 7x inrush
 Fuel 'Pulse' output fixed 1 sec pulse to suit fuel solenoids with separate pull-in coil
 150mA max. (active low) output to drive an external Slave Relay.
 Timed Pre-Heat output user adjustable 0 – 25 sec (set at mid-scale)
 150mA max.(active high) output to drive an external Slave Relay

General Ambient temperature -10⁰C to +55⁰C Operating,
 -25⁰C to +70⁰C Storage

Construction
 Through panel fitting, 72mm sq. DIN standard case. Reversed screen-printed "LEXAN" (or similar) front panel. Printed Circuit Boards varnished as standard.

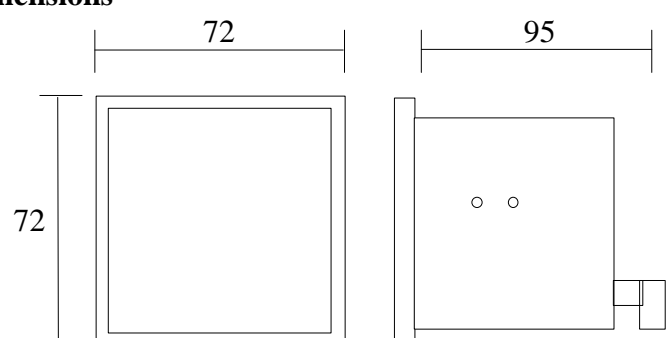
<p>Dimensions</p> 	<p>Notes :</p> <ul style="list-style-type: none"> 1/ Not to Scale 2/ all dimensions in mm 3/ Panel cut-out 68 x 68 mm
--	---

For a spare or replacement unit, please ensure that the 'Serial Number' of the original unit is quoted.



CAPRICORN CONTROLS LIMITED

INDUSTRIAL ELECTRONIC ENGINEERS

SPECIALIST CONTROLS FOR ENGINE APPLICATIONS

Thorpe Close, Banbury, Oxon., OX16 4SW. England

Tel: +44 (0) 1295 272360 Fax: +44 (0) 1295 264766

E-mail: sales@capricorn-controls.com Web: www.capricorn-controls.com

Keystart, Remote Start, Start-on-Demand, Mains Failure, Mutual Standby & Multi-set Controllers. Annunciators and Lamp Modules. Voltage, Current, Frequency, Speed, and Temperature Monitors. Timers. Transport Refrigeration Spares. Batteries, Battery Chargers and Power Supplies. Spares and Accessories. Customised Products and Bespoke Designs.