



RSM72 Remote - Start - Modules

Genset Controls - Timers - Monitors - Trips - Battery Charging Spares - Accessories - Custom Products

These versatile controllers, set in compact 72mm sq DIN sized cases, can provide fully automatic start-up, monitoring and shutdown of Petrol, Diesel or Gas powered engines.

The front panel has up to seven 'High Intensity' LED's indicating system status. A rotary switch (where provided) can select up to four operational modes - see overleaf for more details.

OFF / RESET

Isolates Term.11 & Term.17 from Battery +Ve. Used to manually stop the engine and reset all alarms.

WARNING: This is not an Isolator -- See page-4.

LAMP TEST

(RSM72B-- & RSM72C-- only) Off-Lamp Test-Auto-Man. Lights all LED's and provides a lamp test output (note: AUTO mode active).

AUTO

Switches battery positive to Terminal 17, ready to automatically start the engine (subject to Pre-Heat Time) when Term.17 & Term.18 are externally connected via 'volt-free' contacts. The engine stops immediately this connection is broken, except with the 'Q' option which includes an integral 'Stop Delay' timer.

MANUAL

Starts the engine immediately subject to the Pre-Heat Time, effectively linking Battery +Ve & term.18 internally (except with the 'N' option, see page 8).

TEST

(RSM72G-- only) Off-Auto-Man-Test. Provides an 'active-low' output when the engine has achieved 'crank-cut' speed and no fault shutdown is present. By connecting an external relay between this output and 'fuel solenoid' (term.5), the relay contacts can be used to break the 'mains-failure' sensing at the ATM72 (or other 'Auto-Transfer' circuit) to provide a 'test on load' function.



RSM72C

Dedicated inputs are provided for Cooling Fault (HET) and Low Oil Pressure (LOP) sensors which are disabled at run up until the Hold-Off timer has elapsed to allow the parameters to stabilise. These inputs can be individually configured to sense fault conditions that either close to, or open from -Ve, please specify when ordering.

The auxiliary shutdown channel operates immediately its input is connected to Battery -Ve. It is designed to expand the number of shutdowns using an EXM7-- Expansion Module or relay logic circuits. However, inclusion of the 'X' option provides LED status for this channel, in place of 'DC on' and a variety of 'overstick' labels are available to provide a fourth shutdown channel.

Operation In 'Auto' Mode

The RSM72 consumes little or no power until the 'Remote Start' Terminals 17 & 18 are connected. where upon the Pre-Heat output will activate and the Fuel relay energise. A short time later or after the Pre-Heat timer has elapsed, the Starter Relay will energise (subject to the 'Oil Pressure Safety Circuit' -- see below) and the Pulse Timer starts the Crank cycle. As soon as the engine reaches 'Crank-Cut' speed (typically 40% of rated speed but user adjustable) the Starter relay de-energises and is locked out. If the Crank Cycle times out first, the start relay is de-energised for an equal 'Dwell' period (to allow the starter motor to cool down and the battery to partially recover). The Crank and Dwell cycles are now repeated until the engine starts or the system shuts down on 'Fail to Start' at the end of the third Crank cycle. Note: up to 9 crank cycles can be requested at the time of ordering.

Oil Pressure Safety Circuit: The starter relay can only energise for each Crank Cycle if 'Low Oil Pressure' is sensed, to confirm that the engine is stationary. This is designed to prevent damage to the Starter & Ring Gear in the event of the unit not sensing that the engine has started (i.e. an open-circuit in the case of 'Alternator Sensing' or short-circuit in the case of 'Magnetic Pickup sensing') see page 5 for detailed information.

Assuming that the engine has 'run up to speed', the starter relay will have de-energised and the Hold-Off timer (T0) activated. The tachometer circuitry continually monitors for Overspeed. When the hold-off timer has elapsed, the LOP and HET fault circuits are enabled.

The engine should now be running normally and supplying the load. This is normally controlled via an ATM72 or other Auto-Transfer circuit. Note: In 'Base Load' applications the 'T' option (via an external relay) can be used to control a Load Contactor or Motor breaker.

In the event of a shutdown, the relevant fault Led is lit, the Alarm output is activated, Fuel and Starter relays are locked out and the LOP & HET channels disabled (first-up interlock).

Note: In AUTO mode on 'stand alone' systems, if term.18 is disconnected,

- (a) the set will stop immediately unless the 'Q' option (Stop Timer) is included.
- (b) any shutdown alarm condition will be reset unless an 'L' or 'Q' option is included.

SPACE RESERVED FOR USER NOTES

ORDERING INFORMATION

Model No.	Mode Control	Comment	LED-1 (Red)	LED-2 (Green)
RSM72A	Knob	Off - Auto - Man	DC on	Running
RSM72B	Knob	Off - Lamp Test - Auto - Man	DC on	Running
RSM72C	Knob	Off - Lamp Test - Auto - Man	DC on	Auto-Mode
RSM72F	-----	External	DC on	Running
* RSM72G	Knob	Off - Auto - Man - Test	DC on	Running
RSM72K	Key	Man - Off - Auto	DC on	Auto-Mode
Options		Features ... see text for applications	Term.	
RSM72 - L		Fault Shutdown 'Latch' function. Note: included in the RSM72F		
RSM72 - - M		Magnetic Pick-Up (MPU) speed sensing in place of 'Main Alternator' frequency sensing.	9 & 10	
RSM72 - - - N		External stop / start push button control using an external relay.		
RSM72 - - - - Q		Internal 'Stop-Delay' Timer (includes Latch' function). Note: not available on RSM72F		
RSM72 - - - - - R		'Active-Low' drivers for external lamps &/or relays via a separate 8-way connector.	a ---- h	
RSM72 - - - - - S		'Symbols' on front panel in place of text.		
* RSM72 - - - - - -T		'Active-Low' driver output at the end of T0 period (& no fault shutdown)	7	
RSM72 - - - - - - V		Pre-Heat terminated after T0 time (max. 25sec from crank-cut) to suit certain engines		
* RSM72 - - - - - -W		Latched 'Active-Low' driver output with engine running (crank-cut)	7	
RSM72 - - - - - -X		LED-1 to show 'Aux.' channel 'Status' in place of 'DC on'. Please specify 'overstick' label!		
* RSM72 - - - - - -Y		'Active-Low' Pulsed output for Fuel pull-in coil, typically for YANMAR engines.	7	
Input Phasing				
RSM72 - - -		HET (Cooling Fault) & Lop (Low Oil Pressure) are both 'closed to ground' (Battery -Ve) on fault		
RSM72 - - - / HR		HET Reversed - open from ground (Battery -Ve) on fault		
RSM72 - - - / LR		LOP Reversed - open from ground (Battery -Ve) on fault		
RSM72 - - - / HLR		HET & LOP Reversed - {both of the above} - open from ground (Battery -Ve) on fault		

NOTE: 1/ * These Models & Options are 'Mutually Exclusive' as they all use terminal 7, but for different functions!
 2/ 'Engine Running' is defined as 'crank-cut' lockout having activated (typically at 40% normal speed).
 3/ 'Active-Low' (switching to Battery -Ve) driver output(s) are open collector transistors, each capable of switching 40V / 300mA (non-inductive)
 4/ If you require spare or replacement units with 'Model Numbers' & / or 'Build Options' not listed here --- please contact our sales desk for the latest price and delivery. If possible, please quote the serial No. of the original unit.

PLEASE NOTE : The RSM72A, RSM72B, RSM72C, RSM72G and RSM72K modules were designed to operate with the ATM72 Auto-Transfer Module or SDM72 Start-on-Demand Module.
 For "stand-alone" applications we recommend adding the 'L' or 'Q' option – see text.

SPECIAL BUILDS

RSM72 - - - / - - / X0? These 'X' numbers, indicate non-standard product, which has been manufactured to suit a specific customer. They do not appear in any catalogues and may only be available to the original customer. When re-ordering, please quote the full part number together with the 'Serial Number' of the original unit(s).

Note: The RSM72AL & RSM72KL were previously "--- / X037 " special builds

CUSTOMISED PRODUCTS

If you have a specific requirement that is not listed above; please contact our Sales Desk for a quotation. We can normally customise a standard product within a matter of days in order to provide a prototype (if not, production) unit.

TERMINALS

Always ensure that the correct wire sizes are used and that all terminals are tightened correctly.

Terminal	Description	Input / Output	Connect To -----
1 LOP	Low Oil Pressure	-Ve Input	Low Oil Pressure switch
2 HET	High Engine Temp.	-Ve Input	High Engine Temp. switch
3 Starter	Max. Load 16 Amps (resistive) *	+Ve Output	Solenoid or Solenoid Relay
4 Batt+	Supply +Ve		Battery positive
5 Fuel	Max. Load 16 Amps (resistive) *	+Ve Output	Solenoid or Solenoid Relay
6 Batt -	Common DC -Ve supply		Battery negative
7 EXC+	Fuel+ via a 1A Diode	+Ve Output	(See Ordering Information)
8 C.F.	Charge Failure & Excitation	-Ve Input	Charging Alternator (WL)
9 AC or MPU -	Speed sensing		115/230VAC (Main Alternator or
10 AC or MPU+			Magnetic Pick-Up (see page 4)
11 Manual	'Manual' mode **	+Ve Output	External circuitry -- if required
12 Meter +	Analogue Meter Output	+Ve Output	RPM Meter / DC Voltmeter --- see page 10
13 Pre-Heat	Open Collector Transistor ***	-Ve Output	Pre-Heat control relay
14 Alarm	Open Collector Transistor ***	-Ve Output	Alarm control relay
15 Swt +Ve	Switched +Ve Output	+Ve Output	To power, 'Alarm' relay etc.
16 Aux	Auxiliary Shutdown	-Ve Input	Expansion Module(s) or Spare I/P <input type="checkbox"/>
17 Auto	'Auto' Mode **	+Ve Output	Link to 18 via external 'volt-free'
18 Start	Remote Start	+Ve Input	contacts for Remote Start operation
19 L.T.	Lamp Test	+Ve Input	'Global' Lamp Test circuits

NOTE : * De-rate to 14% for Inductive Loads (2.2A for Relay or (Solenoid) see below

** Limit to 500mA Maximum.

*** Limit to 300mA Maximum. Flywheel diode(s) should be connected across inductive Load(s)

*** **upgraded to 1A Protected outputs as from mod. Number: M0**

WARNING: Fuel & Starter Outputs

Although the on board relays are quite capable of directly switching small solenoids, we would recommend that slave relays are always used as a matter of course unless both the Fuel & Starter Solenoid currents are known, and are within the specification of the RSM72. In line with other manufacturers, we quote the Fuel and Starter outputs as 16A (resistive) which relates to the contact ratings of the internal relays. However, as both Solenoids & Relays are inductive loads this 16A rating must *always* be de-rated to 14%, that is maximum continuous current of 2.2A to allow for a 'seven times' inrush, when the inductive load is energised.

WARNING: "OFF" - mode

In order to maximise flexibility, the mode control is effectively, independent of the '+Ve Start' input on Term.18. Thus, for 'Auto' operation Term.17 (Auto+ O/P) and Term.18 (Start + I/P) **MUST** always be connected via **VOLT-FREE** contacts, as a +Ve DC current applied to Term.18 (ie. via other circuitry) will allow the set to start &/or prevent it from stopping, when 'OFF' mode is selected !

As with all rotating machinery, an Emergency stop facility should be provided.

WARNING: Voltages dangerous to human life

Voltages **dangerous to human life** may be present at some of the terminal connections of this unit. Ensure that all AC and DC supplies isolated before attempting any connection / disconnection.

Basic Connections

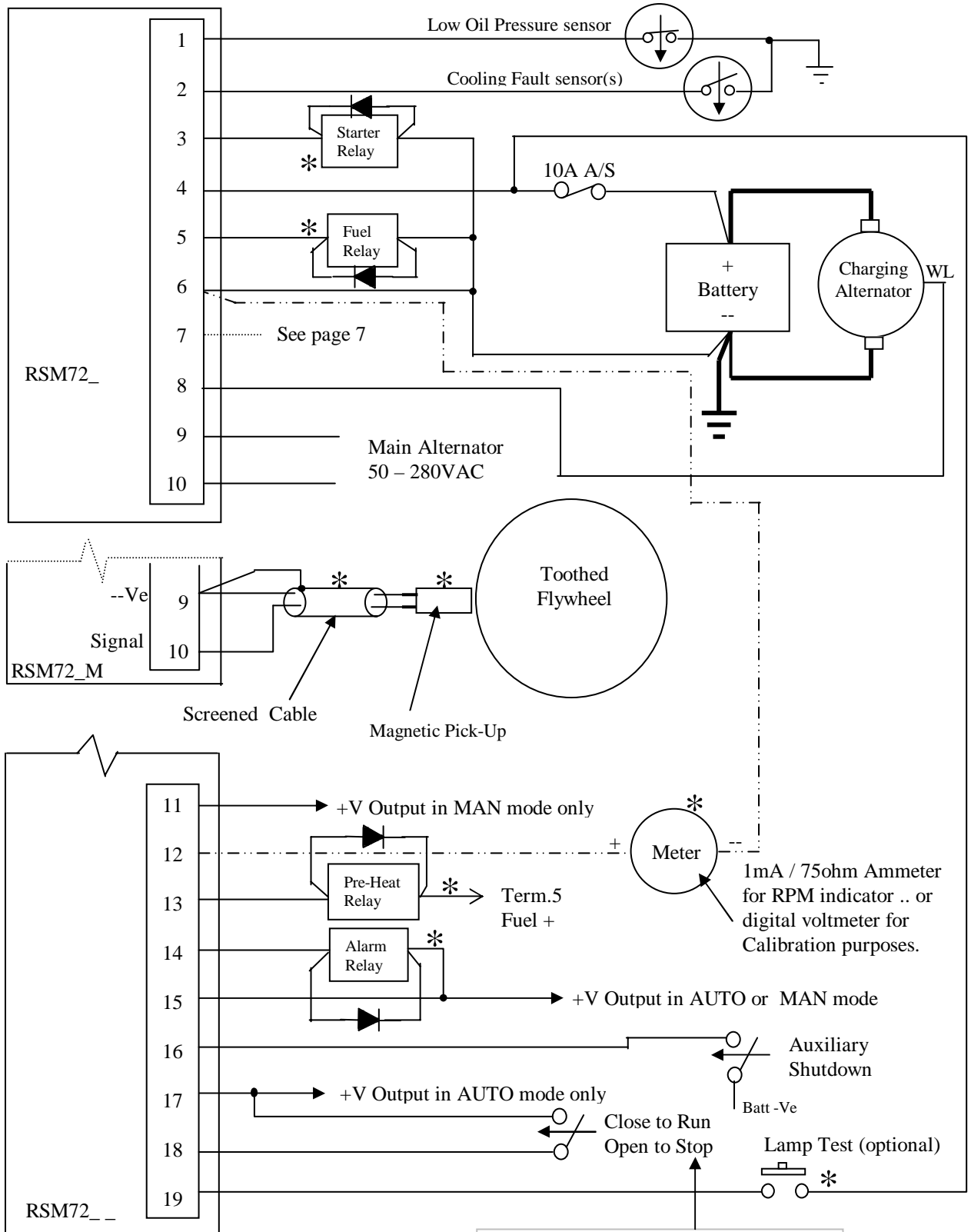

Note: 'Q' option in "AUTO" mode will stop after delay.

- NOTES :
- 1/ Items marked * are generally available 'ex-stock' from Capricorn Controls.
 - 2/ Starter Motor will not operate unless 'Low Oil Pressure' is sensed
 - 3/ Low Oil Pressure & Cooling Fault sensors are shown 'close to ground' on fault
 - 4/ Cooling Fault could be 'High Engine Temp' & / or 'Low Coolant Level'

Low Oil Pressure 'Safety Circuit'

The starter relay cannot energise for each Crank Cycle unless a Low Oil Pressure input is sensed, to confirm that the engine is stationary. This is designed to prevent damage to the Starter Motor & Ring Gear in the event of the RSM72 not sensing that the engine has started (i.e. an open-circuit in the case of 'Alternator Sensing' or short-circuit in the case of Magnetic Pickup sensing).

If a 'Low Oil Pressure' switch cannot be fitted to the engine, the correct solution is to fit a Magnetic Pick-Up. However, if this is not possible the following circuit could be used --

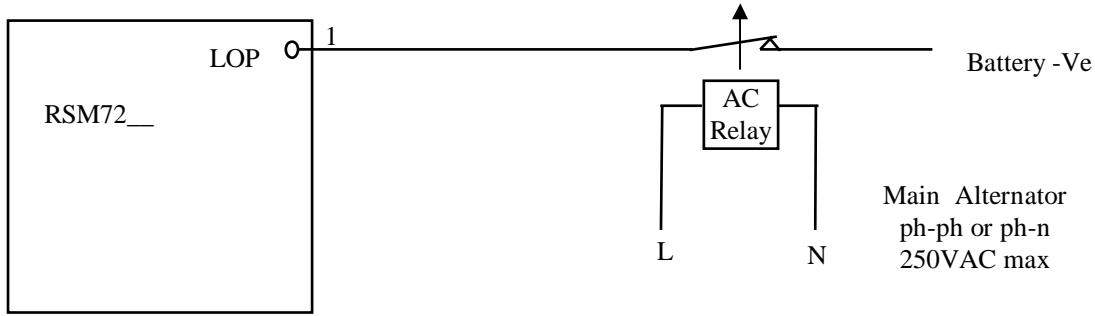

A suitable AC relay connected to the main alternator, as shown above, is de-energised when the engine is stationary. It's N/C contacts connect a Battery -Ve to the 'Low Oil Pressure' input so that the 'Safety Circuit' will enable the Starter Motor output. As the engine runs up to speed and the AC volts rise, the relay will energise and remove the Battery -Ve from the 'Low Oil Pressure' input. In the event of the AC Relay, de-energising while the engine is running normally, the engine will shutdown on the 'Low Oil Pressure' channel.

Note : If an RSM72_/LR (or /HLR) is used (where the 'Low Oil Pressure' input is reversed - to 'open from ground' on fault), the AC Relay contacts must be N/O.

WARNING:

If it is not possible to fit the above circuit (i.e. on a Pump-Set), a low oil pressure switch or a magnetic pick-up, the 'safety-circuit' can be disabled. Please contact the factory for details. However, we do not recommend this course of action as you risk damage to the Starter Motor and Ring Gear, if for whatever reason, the starter should re-engage into a running engine.

A selection of 'over-stick' labels are available to rename the 'Low Oil Pressure' channel. Operation of the RSM72 is not affected if a 'High Engine Temperature' switch is not available. The connection can be left 'open-circuit' or used to sense another fault condition and a blank or named 'over-stick' label can be provided to rename this channel. However, in the case of an RSM72_/HR (or /HLR) where the HET input is 'open from ground' on fault, Term.2 must be wired to Battery -Ve if not used for another fault condition.

Noise Suppression Components

Both AC & DC inductive components (i.e. Relays, solenoids, etc) should be connected as shown --

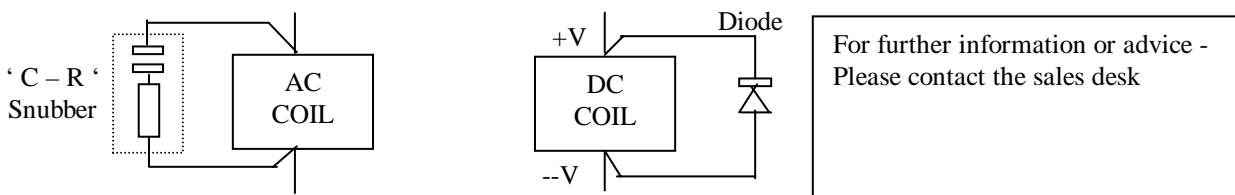

Wiring Instructions for specific Models

1/ **RSM72A---** and **RSM72K---** were designed to operate with our ATM72 'Auto-Transfer Module' or SDM72 'Start-on-Demand module'. The 'A' version has a knob operated mode switch, while the 'K' version is key operated (single numbered key – removable in any position).

RSM72B--- & **RSM72C---** Mode control = Off - **Lamp Test** - Auto - Man. Terminal 19 (Lamp Test) is 'bi-directional'. That is, if an external DC voltage (12 or 24V) is applied to this terminal - all the LED's will light, irrespective of the mode control position. Alternatively, if the Lamp Test position is selected - all the LED's will light and a +Ve DC output (300mA Max) at term.19 can be used to 'globally' Lamp Test other modules &/or discrete circuits. For higher currents a suitable slave relay must be used.

Note: when in Lamp Test mode, 'Auto' operation is still active.

2/ **RSM72F---** External Mode Control only (the 'Q' option does not apply)

These models provide for Stop / Start push button control and / or an external Mode Control Switch.

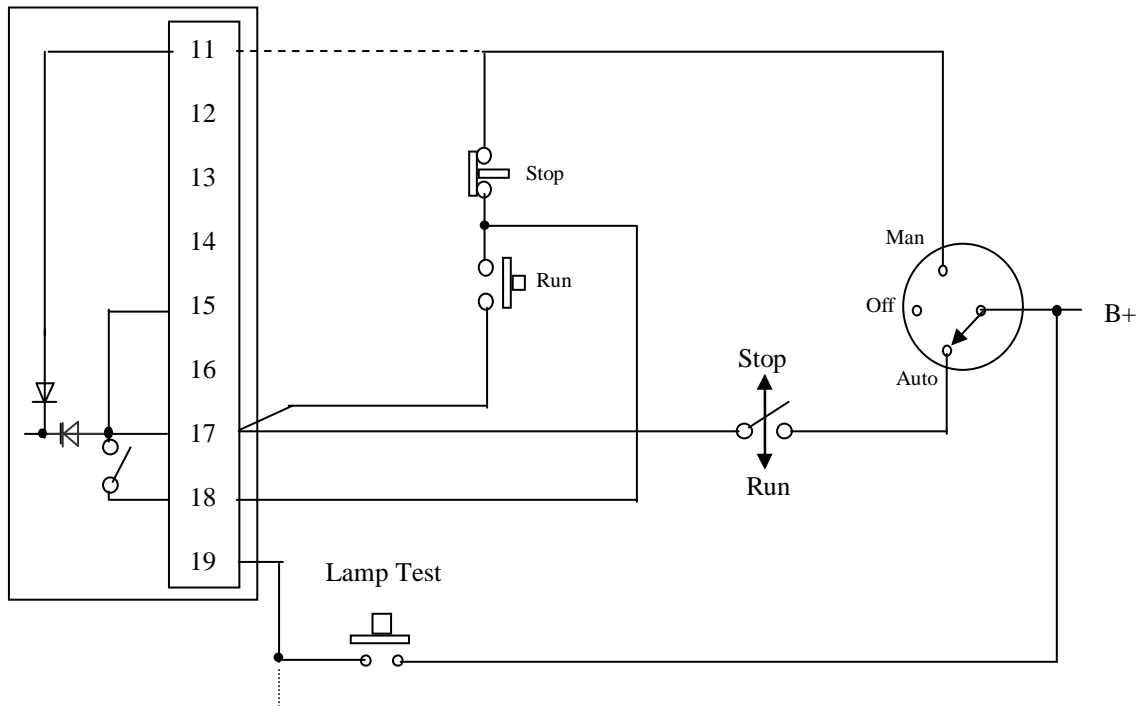

3/ **RSM72G---** Mode Control = Off - Auto - Man - **Test**

Typically used for 'Test on Load', when running in Manual Mode.

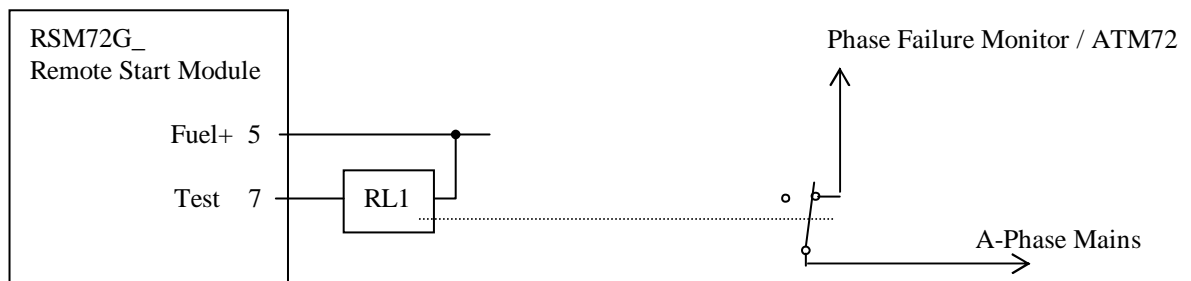

The (open collector transistor) **Test** output (term7 above) switches to battery -Ve (active-low) when the engine has achieved crank-cut speed with no fault shutdown present and 'Test' mode selected.

Relay RL1 (DC coil voltage to suit the Starter Batteries (i.e. 12 or 24VDC) **must be** connected to the Fuel Solenoid supply at term.5 as an internal fly-wheel diode is fitted. RL1 (n/c) contacts would normally be used to break the Mains AC sensing circuits to provide a simulated mains-failure / Test on load.

4/ **RSM72GW---** Mode Control = Off - Auto - Man - **Test**

This version requires term.7 for the 'W' Option (see overleaf). Therefore, the 'Active Low' **Test** output uses Term.13 in place of the 'Pre-Heat' output. Thus, **Pre-Heat, is not available on this build.**

Add the "L" option--- for "stand-alone" applications. An internal latch ensures that the unit remains powered in AUTO mode to indicate fault status if term.18 is disconnected from a +Ve supply after the unit has shutdown on a fault condition.

Add the "Q" option --- for "stand-alone" applications where an integral 'Stop Delay' timer is required. In AUTO mode when the +Ve supply is removed from term.18, the engine will stop after the user adjustable time.
 Note: the 'Q' option also incorporates the 'L' Option, above.

Wiring Instructions for Specific Build 'Options'

1/ **RSM72--M--** Speed sensing via Magnetic Pick-Up (in place of main alternator frequency sensing).

Term. 9 (-Ve) and term.10 (signal) should be connected to the Magnetic Pick-Up terminals via a screened cable.

Always ensure that --

- (a) The screen is **ONLY** connected to term.9 and if wired via a terminal block, that the integrity of the screen is maintained.
- (b) If one Magnetic Pick-Up terminal is connected to the body, the same must be connected to term.9
- (c) The correct gap is set between the Magnetic Pick-Up and a Flywheel tooth.

2/ **RSM72--N--** Provision for external Stop/Start push buttons in **Man** mode

This version requires external connections in order to start the engine in Manual mode

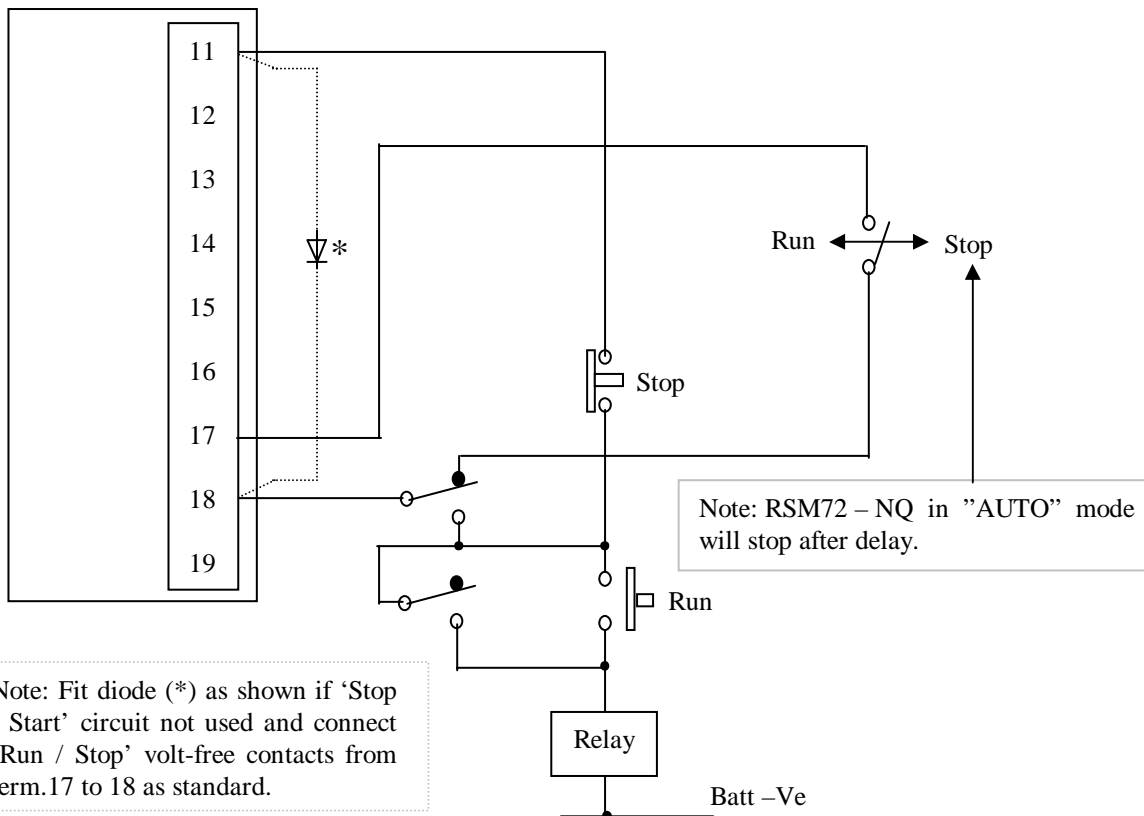

Note: Fit diode (*) as shown if 'Stop / Start' circuit not used and connect 'Run / Stop' volt-free contacts from term.17 to 18 as standard.

Note: RSM72 - NQ in "AUTO" mode will stop after delay.

3/ **RSM72--R--** Seven, 'active-low' drivers allow external lamps &/or relays (150mA / 30VDC max each output) to be connected via an 8 way (top) connector. Typical applications include: remote indication (i.e. using an LPM72 Lamp Module) and volt-free contacts for 'Dial-Out' Alarm Systems.

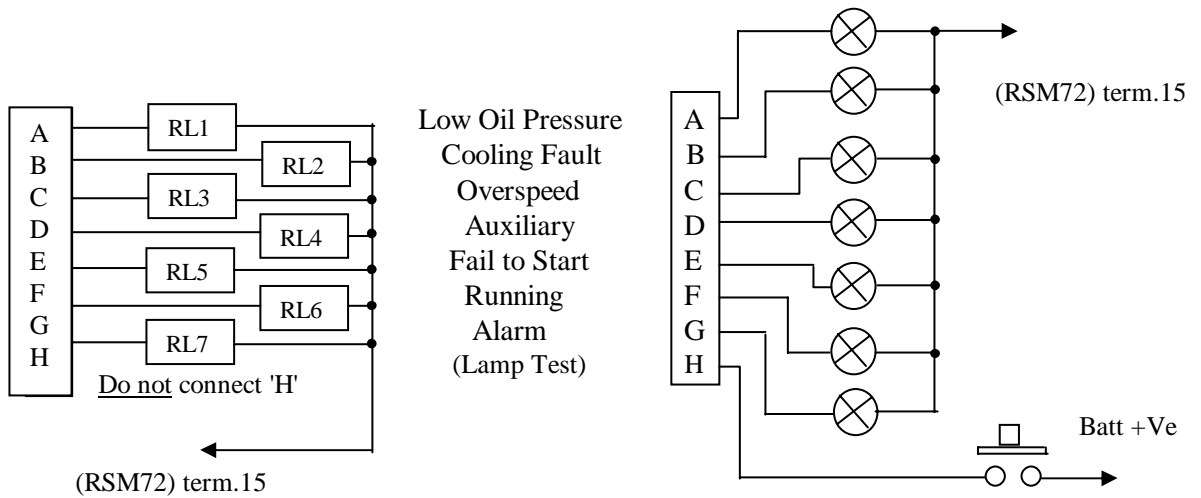

4/ **RSM72—T, & Y--** 'Active-Low' driver output (on term.7)

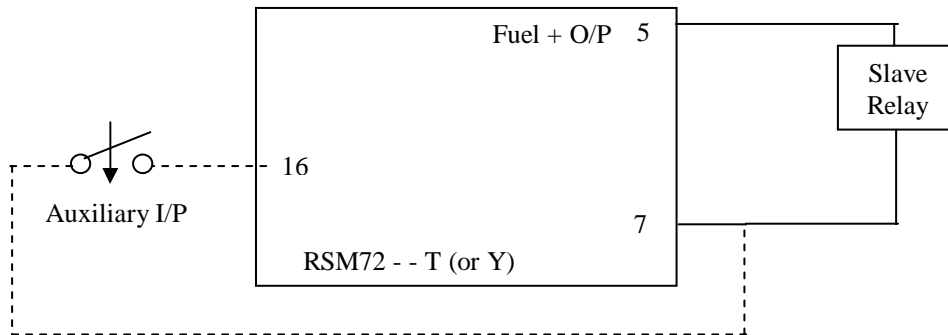

With these options, term.7 is capable of sinking 150mA / 30VDC and is designed to drive an external Slave Relay. The 'T' option connected as shown above (dotted), makes the 'Aux.' channel subject to the 'T0' timer, and provides 'First-up Interlock'. Also, the slave relay (with the 'T' option) could be used to control a Load Contactor for 'stand-alone' applications where the RSM72 is not used with an ATM72 or other 'Auto-Transfer' circuit.

5/ **RSM72--W--** Active-Low 'Enable' driver output (on term.7) at 'Crank-Cut' (engine running). This is normally used with EXM72-W Expansion Modules. In the event of a fault shutdown, this driver output is disabled. This 'Enable' output is capable of sinking 150mA / 30VDC and could be used to drive an external relay or timer (connected to the +Ve fuel solenoid output on term.5)

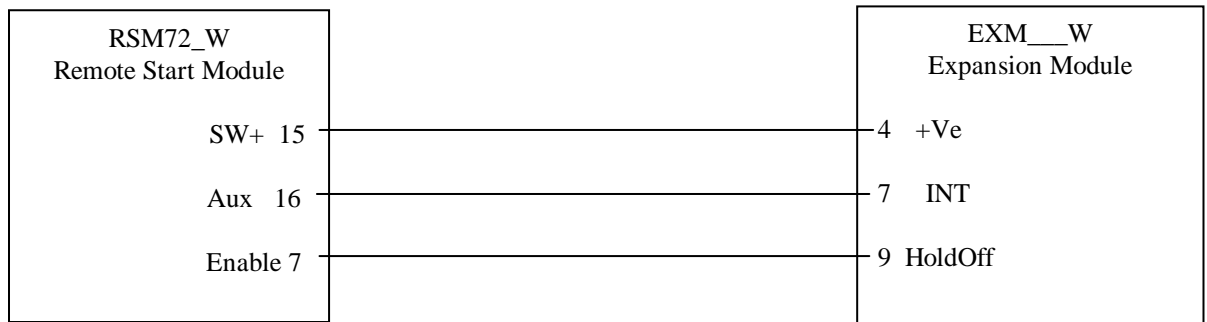

Please refer to the EXM72 'Data & Application Note' for further information

INSTALLATION GUIDELINES

Guidance Information for the Installation of Capricorn Controls products to assist in maintaining Electromagnetic Compatibility.

Every effort has been taken in the design of the products to comply with the CE regulations and standards of Europe.

To maintain the integrity of the product the following general installation instructions are recommended as a good practice.

- 1) Follow the specific installation instructions as supplied with the product.
- 2) Site the product as far as possible physically from known sources of interfering signals.
- 3) Use qualified technicians for the installation.
- 4) All connecting cables are aerials, which can collect interfering signals. Therefore it is good practice to make the interconnecting wires as short as possible, properly terminated and of the correct size and rating.
- 5) Route the product connecting cables, especially control and signal cables away from power cables and cables known to carry high frequency signals. This includes rectifier circuits and AC/DC commutating circuits.
- 6) Where cables have to be run close to interfering sources, use screened cable or twin twisted cable. The screened cables require proper termination of the screen at the ends. This should be co-axial termination where possible and terminated outside of the metal case where the product is housed. Ensure a metal-to-metal contact is made. Pigtail termination of the screen is not good E.M.C practice either at case shielding or at connectors.
- 7) If interference problems still exist, consider using a screened metal enclosure, around either the product or the source of interference. Metal to metal contact should be maintained at all connecting surfaces. Note: Paint is a good insulator and will ruin any measures taken to eliminate Electro magnetic interference.
- 8) Some of the Capricorn Control products are panel mounted. Where these have external controls, electrostatic discharge from operators has been taken into consideration, but require that proper connection to the earth terminal be made.
- 9) If EMC problems exist which cannot be solved by the above advise please contact Capricorn Controls.

The above information is provided as guidance only in good EMC practice and no obligation can be inferred on Capricorn Controls for failure of the product to perform when installed.

APPLICATION EXAMPLE

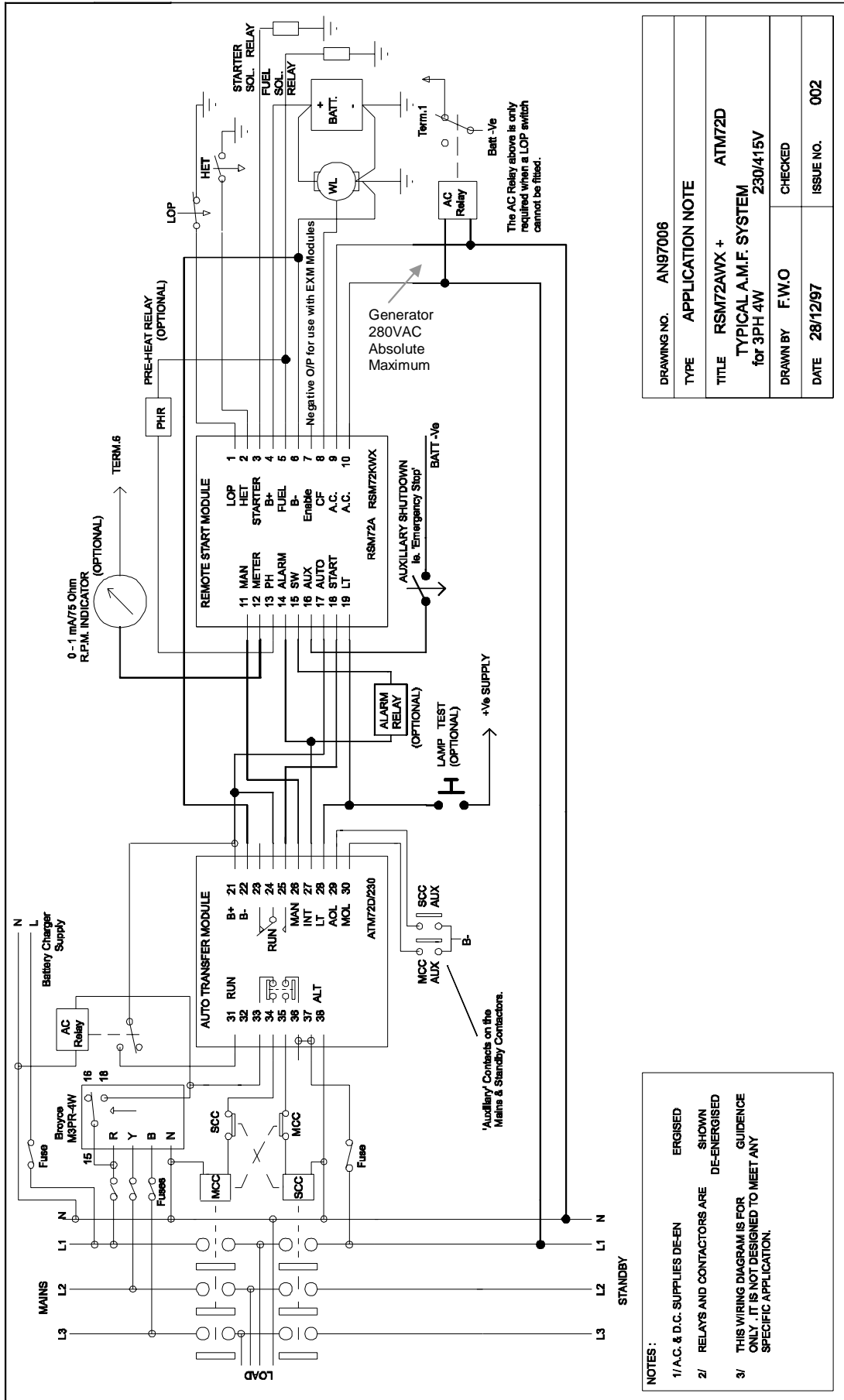

DRAWING NO.	AN97006
TYPE	APPLICATION NOTE
TITLE	RSM72AWX + ATM72D TYPICAL A.M.F. SYSTEM for 3PH 4W 230/415V
DRAWN BY	F.W.O
DATE	28/12/97
CHECKED	
ISSUE NO.	002

NOTES:

- 1/ A.C. & D.C. SUPPLIES DE-ENERGISED
- 2/ RELAYS AND CONTACTORS ARE SHOWN DE-ENERGISED
- 3/ THIS WIRING DIAGRAM IS FOR GUIDANCE ONLY. IT IS NOT DESIGNED TO MEET ANY SPECIFIC APPLICATION.

SPACE RESERVED FOR USER NOTES

ACCESS to POTENTIOMETERS

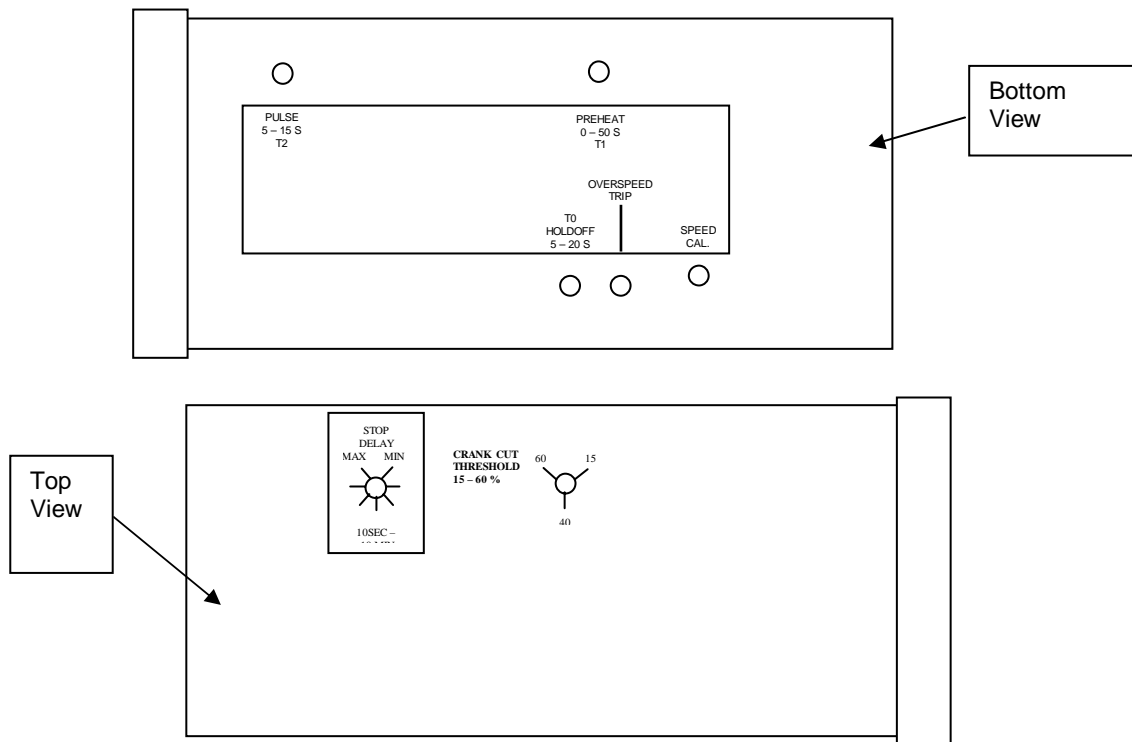

SPEED CALIBRATION

Speed sensing is achieved by monitoring the frequency from either the AC voltage of the main Alternator or a Magnetic Pick-Up sensing flywheel teeth. The tachometer circuitry produces an analogue voltage proportional to engine speed. This voltage is fed to the Meter Output and an internal comparator which is also connected to the 'Overspeed Trip' potentiometer.

'Speed CAL' a 20-turn potentiometer used to Calibrate the meter output to 2.50V at nominal speed (typically 1500rpm, 1800rpm, 3000rpm, 50Hz, 60Hz, etc).

'Overspeed Trip' a single turn potentiometer to set the overspeed trip as a % of nominal speed

'Crank Cut Threshold' a single turn potentiometer to set Crank Cut as a % of nominal speed.

ATTENTION – only use a plastic 'pot-adjuster' or miniature insulated screwdriver to set the potentiometers, otherwise they may be permanently damaged which may impair the reliability of the controller.

In order to calibrate the RSM72 a method of measuring the actual engine speed will be required. Ideally this will be an accurate RPM indicator (separate to anything connected to the meter output of this module). However, a standard frequency meter connected to the main Alternator could be used.

On a running engine

Overspeed Trip setting. Note: this is factory preset at 114% and should not require adjustment

- ◆ Turn the mode switch to Off and ensure that the engine is stationary.
- ◆ Connect a DC Voltmeter to terminal 12 (+) and common -Ve
- ◆ Turn the 'Overspeed Trip' potentiometer fully *anti-clockwise*
- ◆ Calculate the required Voltmeter reading at overspeed ($V_m = 2.5 \times \text{Overspeed} / \text{Nominal Speed}$).
- ◆ Example: $V_m = 2.5 \times (57\text{Hz} / 50\text{Hz}) = 2.85\text{V}$
- ◆ Start the engine
- ◆ Adjust 'CAL' potentiometer until Voltmeter reads the calculated V_m setting (i.e 2.85V)
- ◆ Slowly, turn the 'Overspeed Trip' potentiometer *clockwise* until the unit trips to overspeed.

Re-adjust or Re-calibrate the **Speed CAL** setting

- ◆ Turn the mode switch to Off and ensure that the engine is stationary.
- ◆ Connect a DC Voltmeter to terminal 12 (+) and common -Ve
- ◆ Turn the 'Speed CAL' potentiometer approx. 10 turns anti-clockwise
- ◆ Start the Engine and run at approx. normal speed, **note the actual speed**
- ◆ Calculate the required Voltmeter reading: $V_m = 2.5 \times \text{Actual Speed} / \text{Nominal Speed}$
- ◆ Example: $V_m = 2.5 \times (52\text{Hz} / 50\text{Hz}) = 2.60\text{V}$ (or $V_m = 2.5 \times 1560 / 1500 \text{ rpm} = 2.60\text{V}$)
- ◆ Slowly, adjust 'Speed CAL' potentiometer until Voltmeter reads the calculated V_m setting (i.e 2.60V)

Bench Testing

- ◆ Turn the mode switch to Off .
- ◆ Turn the 'Speed CAL' potentiometer approx. 10 turns anti-clockwise
- ◆ Connect a 12V Battery or suitable power supply to terminals 4 (+) and 6 (-)
- ◆ Connect a DC Voltmeter to terminal 12 (+) and common -Ve

(a) Alternator Frequency Sensing

- ◆ Connect a 50Hz or 60Hz AC mains supply & Frequency meter to terminals 9 & 10
- ◆ Turn the 'Overspeed Trip' potentiometer fully *anti-clockwise*
- ◆ Calculate the required Voltmeter reading : $V_m = 2.5 \times \text{Overspeed} / \text{Nominal Speed}$
- ◆ Example: for 114% Overspeed on a 50Hz generator : $V_m = 2.5 \times (57\text{Hz} / 50\text{Hz}) = 2.85\text{V}$
- ◆ Turn Mode Switch to MAN (power the unit)
- ◆ Adjust 'CAL' potentiometer until Voltmeter reads the calculated V_m setting (i.e 2.85V)
- ◆ Slowly turn the 'Overspeed Trip' potentiometer *clockwise* until the unit trips to overspeed.

Re-adjust the **Speed CAL** setting

- ◆ Turn the 'Speed CAL' potentiometer approx. 10 turns anti-clockwise
- ◆ Turn the Mode Switch to MAN (power the unit)
- ◆ Calculate the required Voltmeter reading: $V_m = 2.5 \times \text{Actual Speed} / \text{Nominal Speed}$
- ◆ Example: $V_m = 2.5 \times (49.5\text{Hz} / 50\text{Hz}) = 2.48\text{V}$
- ◆ Slowly, adjust 'Speed CAL' potentiometer until Voltmeter reads the calculated V_m setting (i.e 2.48V)

(b) Magnetic Pick-Up (MPU) speed sensing

Adjust the **Speed CAL** setting

- ◆ Connect a suitable Oscillator & Frequency meter to terminals 9 & 10 (see below)
- ◆ Calculate MPU frequency $f = (\text{no. of teeth}) \times \text{Normal Speed in RPM} / 60$
- ◆ (example: for 146 teeth at 1500 rpm $f = 3650 \text{ Hz}$)
- ◆ Set Oscillator to MPU frequency (i.e. 3650Hz)
- ◆ Turn Mode Switch to MAN (power the unit)
- ◆ Slowly, adjust 'Speed CAL' potentiometer until Voltmeter reads 2.50Vdc

Adjust **Overspeed Trip** setting

- ◆ Set the Oscillator frequency = %Overspeed x MPU frequency
- ◆ (example: $114\% / 100 \times 3650\text{Hz} = 4161\text{Hz}$)
Note: $V_m \text{ reading} = 2.5 \times \% \text{Overspeed} / 100$ i.e 2.85V at 114% Overspeed
- ◆ Turn Overspeed Trip potentiometer fully anticlockwise
- ◆ Turn the Mode Switch to MAN (powers the unit)
- ◆ Slowly, adjust Overspeed Trip potentiometer clockwise until the module 'just' trips on Overspeed.

NOTE: If possible, use a Magnetic Pick-Up 'Simulator' (available from Capricorn Controls) or a general-purpose oscillator with a 5V 'TTL' Output. This will ensure that the DC Offset level does not change with frequency or amplitude levels. If the DC Offset exceeds +0.7V the RSM72 may not recognise the frequency.

FAULT FINDING ----- RSM72 BASED SYSTEMS

Always check the 'obvious' first ----

- ◆ System correctly wired
- ◆ Correct RSM72 type fitted for the specific application
- ◆ RSM72 suitably calibrated
- ◆ All connections use suitably rated cables to comply with all appropriate regulations.
- ◆ All terminal screw connections tight.
- ◆ Battery(s) charged, in good condition, clean & tight connections and of the correct voltage
- ◆ The Module MUST be fitted in a control panel with adequate protection from extremes of Temperature, Humidity & Vibration

WARNING - Incorrect wiring could damage the module i.e. -

- 1/ Loss of battery negative (term.6)
- 2/ Connecting any 'Active low' outputs (i.e. Pre-Heat, Alarm, etc.) directly to a positive supply.
- 3/ connecting any positive DC outputs (i.e. Starter, Fuel, Exc.+, etc.) directly to a negative supply.
- 4/ connecting any DC terminals to an AC supply.

- **Unit Dead - set will not start :**

Check for battery supply on term.4(B+) and term.6(B-) of the RSM72 using a DC voltmeter or by shorting term.4 to term.19 (lamp test) and observing if the Led's light.

- **Engine starts in MANual mode but not in AUTOMATIC :**

For all models (excluding the RSM72F version) - the module only operates whilst terminals 17 and 18 are connected via external 'volt-free' contacts (ie. remote switch) when in 'Auto' mode.

- **Engine starts &/or not stopping when 'OFF' mode selected :**

There is a positive current path direct to Term.18 when the mode control is in the 'OFF' position (Term.11 & 17 isolated from Battery +Ve). This current path could be direct from the battery or via a de-energised relay or solenoid coil.

- **Engine not stopping when term.18 disconnected:** Manual mode selected or 'Q' option (Stop Delay) fitted.

- **False tripping of Overspeed shutdown :**

- (a) *Module requires calibration (see below)*
- (b) *Open-circuit probe (magnetic pick-up version ONLY). Always use a screened cable where the screen is connected to term.9 (together with signal -Ve) at the controller end only.*
- (c) *Engine 'overspeeding'.*
- (d) *External relays and Contactor coils may require noise suppression components - see page 6.*
- (e) *Check the Overspeed and Nominal Speed calibration – see page 13 & 14*

- **Fuel operates but no Starter :**

- (a) *Preheat timer set near maximum (50secs), wait for this time to elapse.*
- (b) *If 'Low Oil Pressure' is not sensed, a safety circuit locks out the starter motor – see page 6*

- **Engine starts correctly and then shuts-down on 'Fail to Start' :**

- (a) *Short-circuit probe or probe too far from flywheel teeth (magnetic pick-up version ONLY).*
- (c) *AC sensing version - short-circuit, open-circuit or with a voltage <50VAC or frequency incompatible with the RSM72 type fitted.*

- **No Pre-Heat output :** Pre-Heat timer (0 - 50 sec) factory set at minimum, adjust to suit application.

- **Cooling Fault (High engine temp.) shutdown & / or Low oil pressure shutdown :**

- (a) *Faulty sensor switch, incorrect type(s) or trip setting(s)*
- (b) *Incorrect RSM72 options selected for use with engine switch(es) fitted*

- **Charging Alternator fails to excite :**

- (a) *incorrect type of RSM72 fitted*
- (b) *rear mounted 82R resistor damaged, missing or too high a value (may require external 47R Resistor + 1A Diode on certain 12VDC Alternators – if in doubt, contact Capricorn Controls).*
- (c) *charge fail (term.8) not connected to WL. connection on the charging alternator*
- (d) *charging alternator may require a separate 'Ignition' connection (i.e. from Fuel Solenoid output).*

SPECIFICATION

Supply

12 / 24V Single range supply, operating from 4V to 40VDC (absolute Minimum / Maximum)

Speed Sensing

Magnetic Pickup ('M' option) 600 Hz to 6 kHz at rated speed. (5V to 100Vac pk - pk)

Factory calibrated at 3150Hz unless requested otherwise

Alternator

50 Hz to 400 Hz at rated speed. (30V to 280V Rms. absolute Maximum)

Factory calibrated at 50Hz unless requested otherwise

Adjustable Functions

Pre-Heat Timer 0 - 50 sec (set at 0) unless requested otherwise

Pulse Timer 5 - 15 sec (set at 10sec) unless requested otherwise

Hold-Off Timer 5 - 25 sec (set at 15sec) unless requested otherwise

Stop Timer ('Q' option) 10s - 10 min (set at 5min) unless requested otherwise

Speed Calibration Set 'Cal' potentiometer for meter output = 2.50Vat Nominal Speed

Crank Cut Level 15 - 60% of Rated Speed (factory set at 40% unless requested otherwise)

Overspeed Trip Level 102 - 125% of Rated Speed (set at 114% unless requested otherwise)

General

Ambient temperature -10⁰C to +55⁰C Operating, -25⁰C to +70⁰C Storage

Construction

Through panel fitting, 72mm sq. DIN standard case. Reverse screen-printed "LEXAN" front panel.
Printed Circuit Boards are varnished as standard.

Dimensions

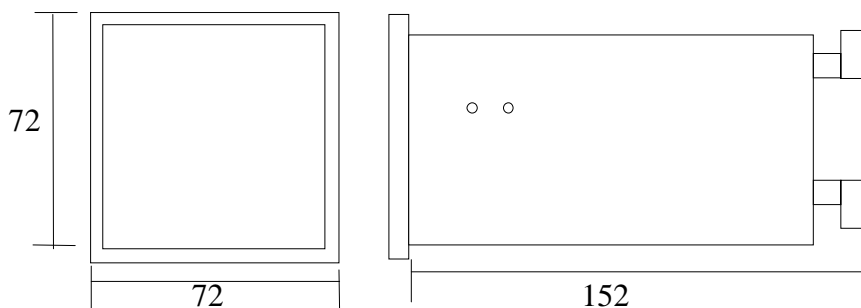

Notes:

- 1/ Not to Scale
- 2/ All dimensions in mm
- 3/ Panel cut-out
68 x 68 mm

Mounting

The module must be fitted into a suitable control panel that provides adequate protection from the extremes of Temperature, Humidity & Vibration. If this control panel is set-mounted then suitable 'Anti-Vibration' mounts MUST be used

For specific information or a replacement unit, please ensure that the 'Serial Number' of the original unit is quoted.



CAPRICORN CONTROLS LIMITED

ELECTRONIC ENGINEERS. Est 1988

SPECIALIST CONTROLS FOR ENGINE APPLICATIONS

Thorpe Close, Banbury, OX16 4SW. England

Tel: +44 (0) 1295 272360 Fax: +44 (0) 1295 264766

E-mail: sales@capricorn-controls.com Web: www.capricorn-controls.com

Keystart, Remote Start, Start-on-Demand, Mains Failure, Mutual Standby & Multi-set Controllers. Annunciators and Lamp Modules. Voltage, Current, Frequency, Speed, and Temperature Monitors. Timers.

Transport Refrigeration Spares. Batteries, Battery Chargers and Power Supplies. Spares and Accessories. Customised Products and Bespoke Designs.